

ForeSite Designs®

For Those Who Envision Tomorrow

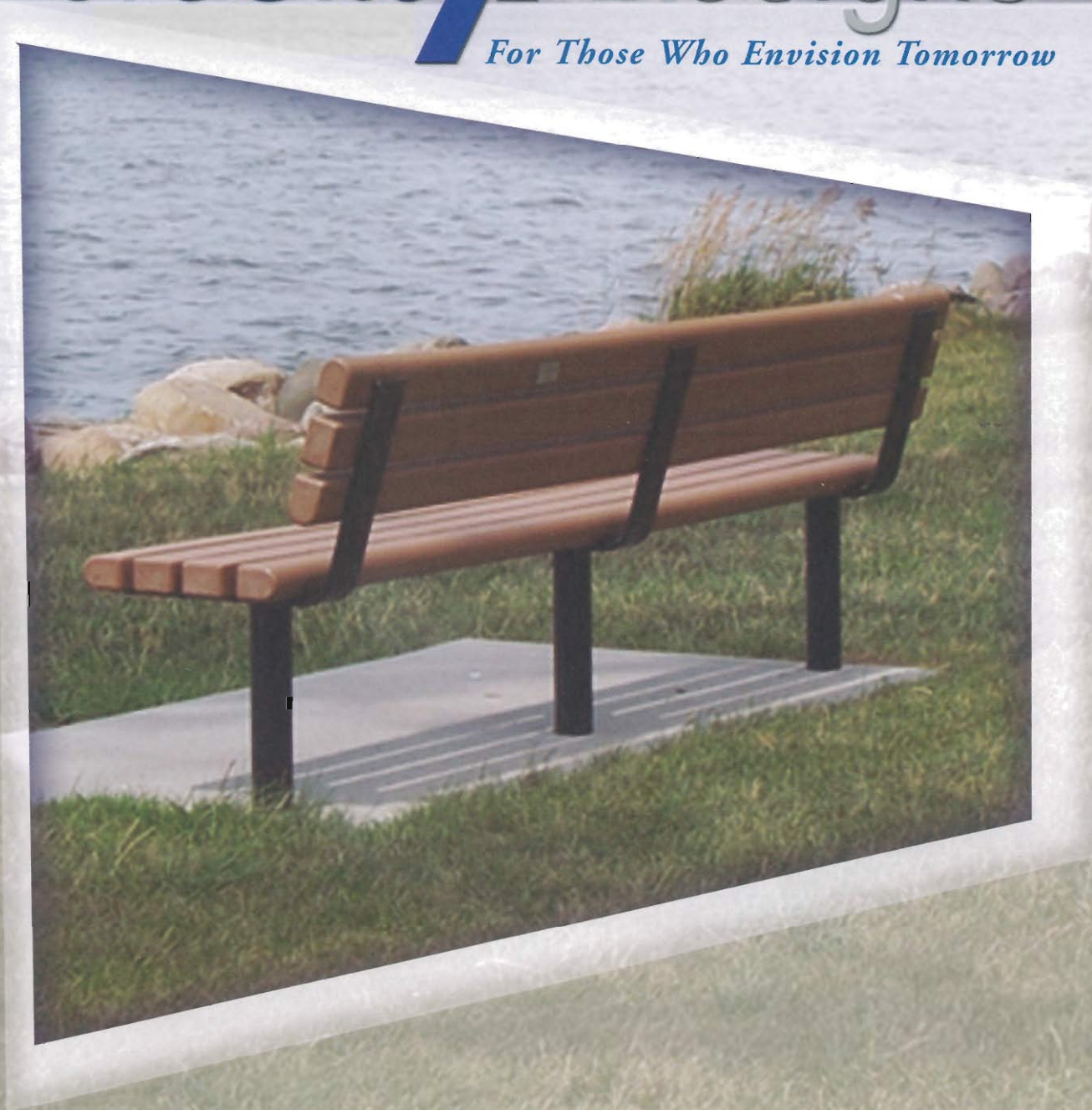

ForeSite Designs® site furnishings, a division of Bedford Technology LLC, has been manufacturing quality site amenities since the spring of 2002. Created by our in house staff of engineers and design professionals, ForeSite Designs® offer low maintenance, highly functional furnishings that are also aesthetically pleasing. Available in two distinct styles; the classic Park Avenue™ or the conventional Park Scape™. Both series include benches, seats, picnic tables and coordinating waste receptacles and are offered in a variety of frame and slat color options.



Park Avenue™ Series



Park Scape™ Series



Park Avenue™ Series Pages 2-4

Park Scape™ Series Pages 5-7



Hex Tables Page 8



Waste Receptacles Page 9

Overview Page 10



Made in USA

Park Avenue™ Series



Park Scape™ Series



Park Avenue™ Series



Benches

- 2"x4" Select™ solid core recycled plastic lumber
- UV protection to guard against color fade
- Rounded seat and back edges for added comfort
- Sand cast aluminum frames with polyester powder coating
- Modular frames allowing for linking options
- Proportioned for sitting comfort
- Generous end arms for comfort and style
- Center arm available

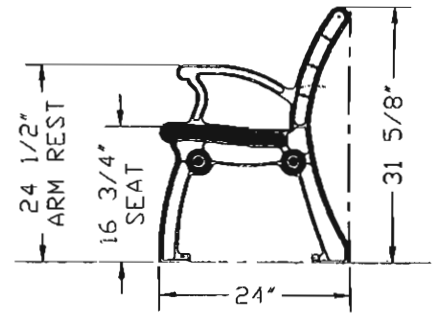

Benches

Model		Weight Lbs.
4005	24" Chair	80
4004	49"	108
4000	60"	124
4001	72"	140
4002	96"	188
4003	Center Arm	4





Seats

- 2"x4" Select™ solid core recycled plastic lumber
- UV protection to guard against color fade
- Rounded seat and back edges for added comfort
- Sand cast aluminum frames with polyester powder coating
- Modular frames allowing for linking options
- Proportioned for sitting comfort



Seat

Model	Length	Weight Lbs.
3004	49"	54
3000	60"	72
3001	72"	80
3002	96"	97

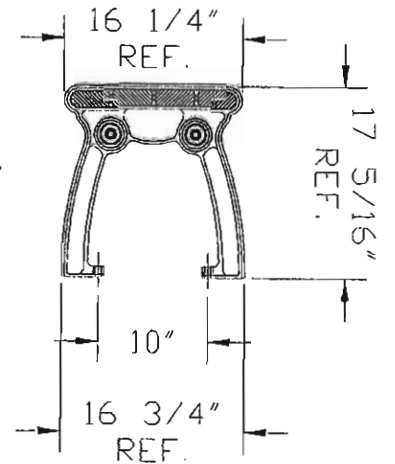

Picnic Tables

- Park Avenue™ Seat used as seat
- Detailed end castings
- ADA configuration available
- Custom sizes available

Picnic Tables

Model	Length	Weight Lbs.
5000	60"	380
5001	72"	412
5004	72"ADA	432
5002	96"	520
5003	96"ADA	530



Park Scape™ Series



The Park Scapes™ series offers conventional design that fits nicely into any park and recreation application. These durable and low maintenance seats, benches and picnic tables are constructed with Select™ solid core recycled plastic slats and polyester powder coated finish on heavy-duty steel frames. Available with or without arm rests. The Park Scapes™ series will look great for years to come. Available in a variety of frame and slat colors.

*Assembly Required. Mounting Options: Embedded, Surface and Portable
Specify model number, mounting preference, frame and slat colors*





Benches

- 3"x4" Select™ solid core recycled plastic lumber
- UV protection to guard against color fade
- Rounded seat and back edges for added comfort
- Heavy duty steel frames with polyester powder coating
- Available with or without arm rests



Benches

Model		Weight Lbs.
1405	24" Child's w/o arms	153
1404	48" w/o arms	164
1400	60" w/o arms	185
1401	72" w/o arms	205
1402	96" w/o arms	249
150	448"	180
1400	60"	201
1501	72"	221
1502	96"	265

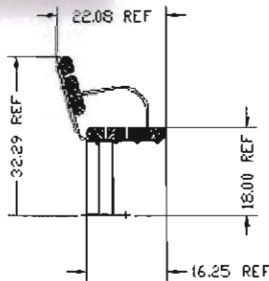

Seat

Model		Weight Lbs.
1870	24" Childs Seat	75
1890	48"	88
1900	60"	107
2000	72"	129
2100	96"	188



Seats

- 3"x4" Select™ solid core recycled plastic lumber
- UV protection to guard against color fade
- Rounded seat edges for added comfort
- Heavy duty steel frames with polyester powder coating
- Proportioned for sitting comfort



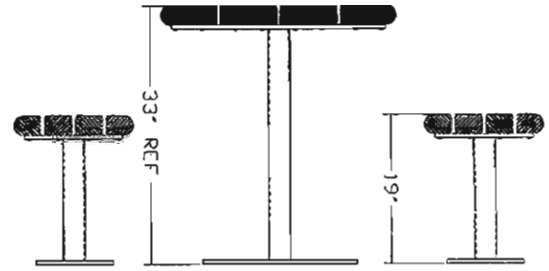

PICNIC TABLES

- Park Scape™ seats used for seating
- ADA configuration available

PICNIC TABLES

Model	Width	Weight Lbs.
1600	60"	425
1700	72"	495
1701	72" ADA	495
1800	96"	633
1801	96" ADA	583



72" ADA TABLE

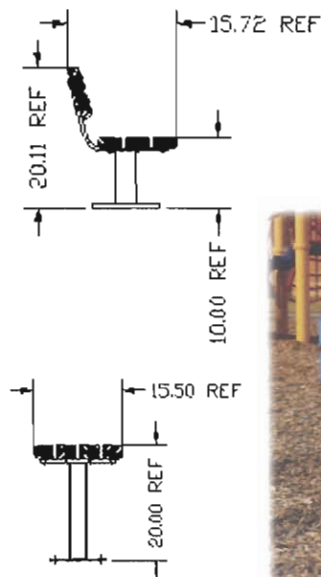

CHILD

Model	Width	Weight Lbs.
1870	24"	75
1405	24"	153



New Design



- *Rounded seat edges for added comfort*
- *Seats six in comfort*
- *ADA configuration available*
- *Surface mounting or free standing*
- *Easy access to seating from either side*
- *Optional 1^{1/2}" umbrella hole with an underside steel support in the table center*

Dimensions

Table top / both = 40.75" edge to edge

Seat / both = 69.7" edge to edge

Standard = 73.1" point to point

ADA = 77.3" point to point

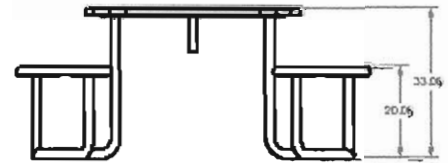
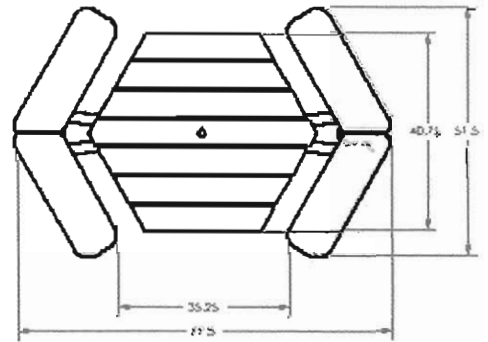

Hex Table

Model		Weight Lbs.
2300	Hex Table	425
2301	Hex Table	350
2302	Hex Table w/umbrella mount	430
2303	Hex Table ADA w/umbrella mount	355



ForeSite Designs® waste receptacles coordinate with both Park Avenue™ and Park Scapes™ series site furnishings. Available in round or square styles.

- 32 gallon capacity
- Liners included
- All fasteners are stainless steel tamper proof to prevent corrosion & theft
- Slats are Select™ recycled plastic lumber
- Frames are sturdy aluminum supported by interior steel bands
- Powder coated polyester finish on all metal parts to protect and seal
- Surface or portable mount
- Anchors available for surface mount units

Specify model number, lid preference, frame and slat colors



Waste Receptacles (Round)

Model 6000 *Steel powder coated dome with hinged door*

Model 6001 *Aluminum powder coated dome with three side access*

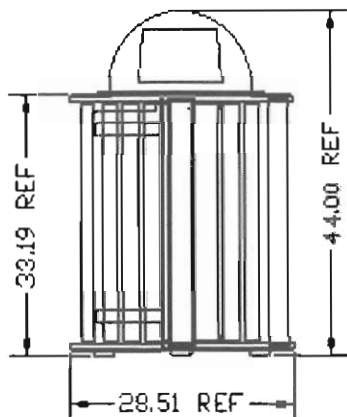

- Hinged locking door with side entry for easy access
- Interchangeable domes

Waste Receptacles and Recycle Containers (Square)

Model 6100
9" round opening

Model 6101
4.5" round opening

Model 6102
3"x9" oblong opening

- Interchangeable lids made from high density poly-ethylene
- Top fill only

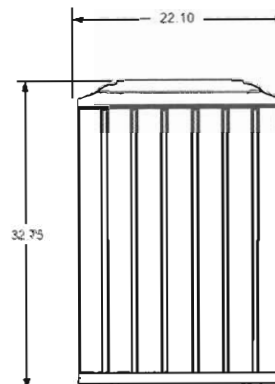

All colors available for both Park Avenue™ and Park Scapes™

Select™ Slat Colors: Cedar, Mink, Weathered Wood, Brown, Gray, Dark Gray, Forest Green, Blue, Yellow, Black, White



Frame Colors: Black, Forest Green, Brown, Gray, Red, White



Plastic Slats

Select™ slats are made from recycled high density polyethylene. UV protection has been added to guard against color fade. Because this is an all plastic product, no water proofing, painting, staining or similar maintenance is required. Can be easily cleaned with light power wash or household cleaners.

Powdercoat Finishes

All ForeSite Design® frames go through a 9 step polyester powder coating process. The end result is a long lasting protection that offers true color and superior chip resistance.

Warranty Information

Effective from the time of invoice through a period of fifty (50) years, the Select™ boards are guaranteed not to suffer structural damage from termites or fungal decay, will not rot, split, crack or splinter. A

limited twenty (20) year warranty is issued against structural failure of the frames. All other pieces have a one (1) year limited warranty.

(A complete copy of the warranty is available upon request)



Distributed by:

ForeSite  Designs®

www.plasticboards.com